

**TENDER SPECIFICATION FOR OVERHAULING OF MAIN ROTOR DAMPER ASSY
AW109E HELICOPTER**

1. **Item's Identification.**

- a. Applicable Aircraft Model : AW109E
- b. Name of the system : Main Rotor system.
- c. Name of the Item : Main Rotor Damper Assy.
- d. Part No : 109-0112-38-103
- e. Serial No : 1252, 1253, 1254 & 1256.
- f. Manual Parts Catalogue Reference: IETP (Chapter 05-10)

2. **Purpose.** The purpose of the damper is to provide the necessary lag motion damping to avoid a blade shock during rotor start rotor brake application and flight maneuver.

3. **Description of Defect/ Maintenance.** Scheduled overhauling (TBO: 1200 flight hours as per Maintenance Planning Manual (MPM), Section 05-10)

4. **Quantity.** 04 in no (01 set)

5. **Technical Specification.**

- a. Dimension (L x B x H) (Each) : (29 x 12 x 10) inches.
- b. Weight of servo actuator : 2.5 kg each x 04= 10 kg (without carton),
with carton 15kg (approx).
- c. Operating Pressure : 30.7 bar
- d. Test Pressure(Internal chambers): 45 bar
- e. Test Pressure(Body) : 4.5 bar
- f. Burst Pressure : 77 bar
- g. Limit Load : 2000 daN
- h. Reservoir Pressure : From 1 to 3 bar

6. **Name of Main Equipment.** Main Rotor

7. **Manufacturer Details.** Mecaer, Meccanica Aeronautica S.p.A.
Via per Arona, 46 Borgomanero (No) Italy
Tel. (+39) 0322-83711
Fax (+39) 0322- 844081
E-mail: www.mecaer.it

8. **Source of Overhaul.** OEM/ OEM authorized service centre.

9. **Scope of Work.** Supplier will perform the following works as per component maintenance manual from OEM/ OEM authorized EASA Part 145 approved organization:

- a. To carryout overhauling as per component maintenance manual and technical instruction provided by Mecaer Meccanica Aeronautica.
- b. To ensure corrosion inspection and maintain corrosion protection.
- c. Functional test is to be carried out as per the manual.

10. **Test, Trial and Acceptance.** Final acceptance will be given by CINS after satisfactory test and trial in BN Helicopter Flight Line.

11. **Warranty.**

- a. A warranty certificate is to be submitted for at least 12 months from the date of acceptance of the items after satisfactory test/ trial as applicable.

b. If any defect/ discrepancy arises, within warranty period, then the respective item is to be repaired at free of cost providing ARC including freight within 02 (two) months from the date of notification of the same to the supplier

c. Warranty period will be extended for the same amount of time the item will remain non-operational.

12. **Bidder's Identification and Qualification.**

a. **Bidder Address (Full address, Contact no and E-mail address):** To be mentioned.

b. **Principal's Address (Contact no and Email address):** To be mentioned.

c. **Principal's Qualification. Only OEM/ OEM authorized or Aircraft OEM authorized principal can submit quotation. Authorized/ Authenticity Certificate by Vendor/ Aircraft OEM (Original copy/ color photocopy to be submitted with offer).**

13. **Certification.**

a. **During Quotation.**

1. The bidder is to provide an Authenticity Certificate from OEM (Equipment/ Aircraft) or OEM (Equipment) authorized principal

2. The bidder is to provide EASA Part 145 certificate (Authorized for aircraft maintenance) of service center.

b. **During Delivery of Item**

1. The bidder is to provide an Authorized Release Certificate (ARC).

2. On completion of overhauling and Log card should be updated with signature and stamp.

3. Work report with list of replaced item is to be provided with the item.

4. The bidder is to provide Certificate of Warranty with the item.

14. **Handling of Item.**

- a. Delivery Point : NSD, Chattogram
 b. Country/ Port of Shipment : To be mentioned.
 c. Shipment (Air/ Sea) : To be mentioned.
 d. Delivery time : 90 days from the date of purchase order provided.
 e. Consignee : For shipment of the unit, consignee should be as mentioned below.

Commanding Officer
 Naval Stores Depot
 New Mooring
 Chattogram- 4218

Or

Officer In-charge
 Naval Stores Sub Depot, Dhaka
 Naval Unit, Khilkhet
 Namapara, Dhaka-1229

15. Terms of Payment.

- a. Price : To be mentioned in Local Currency (BDT).
- b. Applicable Tax/ VAT : Local tax/VAT will be borne by supplier.
- c. Supplier will bear all cost for transporting items to/ from overseas.
- d. After satisfactory test/ trial and acceptance by BN, 100% payment will be made in local currency as per the existing rule.

16. Bidding Conditions.

- a. Offer Validity : The offer should remain valid up to 180 days.
- b. Compliance Statement : A compliance statement fulfilling all the requirement of the tender is to be submitted for evaluation of the quotation. An incomplete compliance statement may attribute to the cancellation of the offer. If any clause of this specification does not commensurate with offer, the deviation has to be clearly mentioned.

17. Figure.

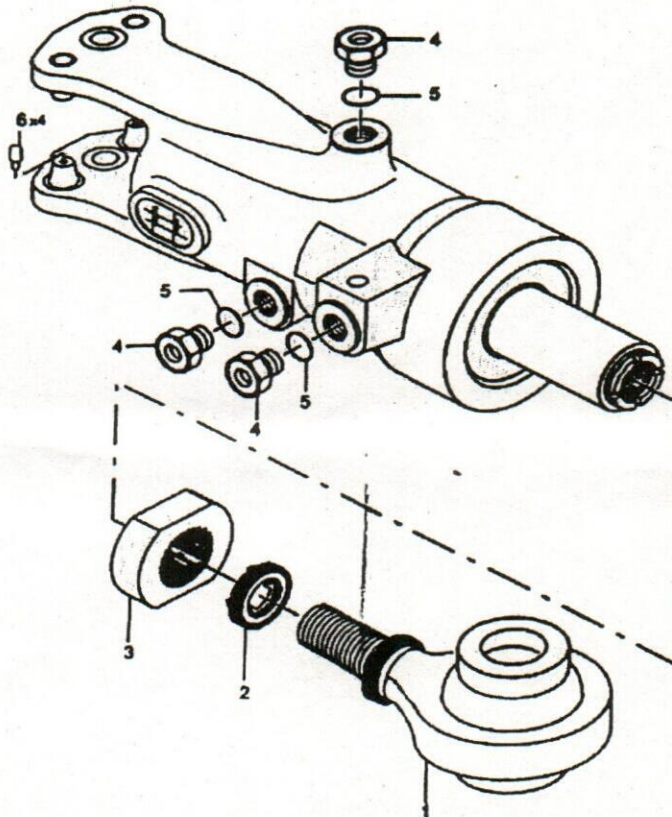

ICN-08-V-622101-G-00001-01326-A-02-1

Fig: Damper Assy

 05.09.24
 SHAHNUR TALUKDAR MUNNA
 Lt Commander BN
 Air Engineer Officer
 H. I Flt Lt Col
 Naval Aviation